

UAF42

UNIVERSAL ACTIVE FILTER

FEATURES

- VERSATILE—
LOW-PASS, HIGH-PASS
BAND-PASS, BAND-REJECT
- SIMPLE DESIGN PROCEDURE
- ACCURATE FREQUENCY AND Q —
INCLUDES ON CHIP 1000pF $\pm 0.5\%$
CAPACITORS

APPLICATIONS

- TEST EQUIPMENT
- COMMUNICATIONS EQUIPMENT
- MEDICAL INSTRUMENTATION
- DATA ACQUISITION SYSTEMS
- MONOLITHIC REPLACEMENT FOR UAF41

DESCRIPTION

The UAF42 is a universal active filter which can be configured for a wide range of low-pass, high-pass, and band-pass filters. It uses a classical state-variable analog architecture with an inverting amplifier and two integrators. The integrators include on-chip 1000pF capacitors trimmed to 0.5%. This solves one of the most difficult problems of active filter design—obtaining tight tolerance, low-loss capacitors.

A DOS-compatible filter design program allows easy implementation of many filter types such as Butterworth, Bessel, and Chebyshev. A fourth, uncommitted FET-input op amp (identical to the other

three) can be used to form additional stages, or for special filters such as band-reject and Inverse Chebyshev.

The classical topology of the UAF42 forms a time-continuous filter, free from the anomalies and switching noise associated with switched-capacitor filter types.

The UAF42 is available in 14-pin plastic DIP and SOL-16 surface-mount packages, specified for the -25°C to $+85^{\circ}\text{C}$ temperature range.

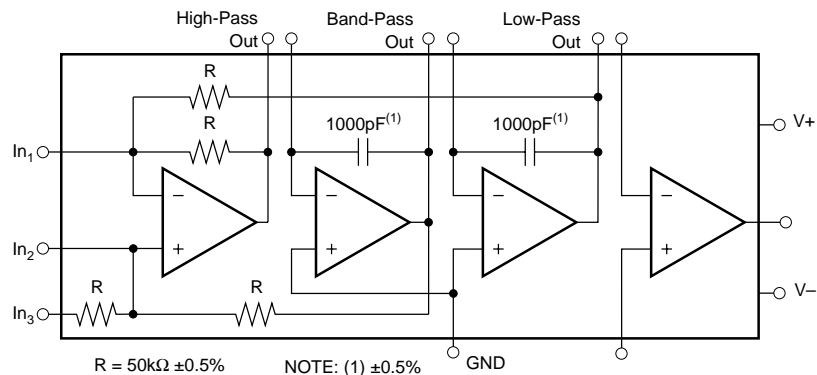

International Airport Industrial Park • Mailing Address: PO Box 11400, Tucson, AZ 85734 • Street Address: 6730 S. Tucson Blvd., Tucson, AZ 85706 • Tel: (520) 746-1111 • Twx: 910-952-1111
Internet: <http://www.burr-brown.com/> • FAXLine: (800) 548-6133 (US/Canada Only) • Cable: BBRCORP • Telex: 066-6491 • FAX: (520) 889-1510 • Immediate Product Info: (800) 548-6132

SPECIFICATIONS

ELECTRICAL

At $T_A = +25^\circ\text{C}$, $V_S = \pm 15\text{V}$, unless otherwise noted.

PARAMETER	CONDITIONS	UAF42AP, AU			UNITS
		MIN	TYP	MAX	
FILTER PERFORMANCE Frequency Range, f_n Frequency Accuracy vs Temperature Maximum Q Maximum (Q • Frequency) Product Q vs Temperature Q Repeatability Offset Voltage, Low-Pass Output Resistor Accuracy	$f = 1\text{kHz}$ $(f_o \cdot Q) < 10^4$ $(f_o \cdot Q) < 10^5$ $(f_o \cdot Q) < 10^5$		0 to 100 0.01 400 500 0.01 0.025 2	1	kHz % %/°C — kHz %/°C %/°C % mV %
OFFSET VOLTAGE⁽¹⁾ Input Offset Voltage vs Temperature vs Power Supply	$V_S = \pm 6$ to $\pm 18\text{V}$		± 0.5 ± 3 96	± 5	mV $\mu\text{V}/^\circ\text{C}$ dB
INPUT BIAS CURRENT⁽¹⁾ Input Bias Current Input Offset Current	$V_{CM} = 0\text{V}$ $V_{CM} = 0\text{V}$		10 5	50	pA pA
NOISE Input Voltage Noise Noise Density: $f = 10\text{Hz}$ $f = 10\text{kHz}$ Voltage Noise: BW = 0.1 to 10Hz Input Bias Current Noise Noise Density: $f = 10\text{kHz}$			25 10 2 2		$\text{nV}/\sqrt{\text{Hz}}$ $\text{nV}/\sqrt{\text{Hz}}$ $\mu\text{Vp-p}$ $\text{fA}/\sqrt{\text{Hz}}$
INPUT VOLTAGE RANGE⁽¹⁾ Common-Mode Input Range Common-Mode Rejection	$V_{CM} = \pm 10\text{V}$	80	± 11.5 96		V dB
INPUT IMPEDANCE⁽¹⁾ Differential Common-Mode			$10^{13} \parallel 2$ $10^{13} \parallel 6$		$\Omega \parallel \text{pF}$ $\Omega \parallel \text{pF}$
OPEN-LOOP GAIN⁽¹⁾ Open-Loop Voltage Gain	$V_O = \pm 10\text{V}$, $R_L = 2\text{k}\Omega$	90	126		dB
FREQUENCY RESPONSE⁽¹⁾ Slew Rate Gain-Bandwidth Product Total Harmonic Distortion	$G = +1$ $G = +1$, $f = 1\text{kHz}$		10 4 0.0004		$\text{V}/\mu\text{s}$ MHz %
OUTPUT⁽¹⁾ Voltage Output Short Circuit Current	$R_L = 2\text{k}\Omega$	± 11	± 11.5 ± 25		V mA
POWER SUPPLY Specified Operating Voltage Operating Voltage Range Current		± 6	± 15 ± 6	± 18 ± 7	V V mA
TEMPERATURE RANGE Specification Operating Storage Thermal Resistance, θ_{JA}		-25 -25 -40		+85 +85 +125	°C °C °C °C/W

* Same as specification for UAF42AP.

NOTES: (1) Specifications apply to uncommitted op amp, A_4 . The three op amps forming the filter are identical to A_4 but are tested as a complete filter.

The information provided herein is believed to be reliable; however, BURR-BROWN assumes no responsibility for inaccuracies or omissions. BURR-BROWN assumes no responsibility for the use of this information, and all use of such information shall be entirely at the user's own risk. Prices and specifications are subject to change without notice. No patent rights or licenses to any of the circuits described herein are implied or granted to any third party. BURR-BROWN does not authorize or warrant any BURR-BROWN product for use in life support devices and/or systems.



PIN CONFIGURATION

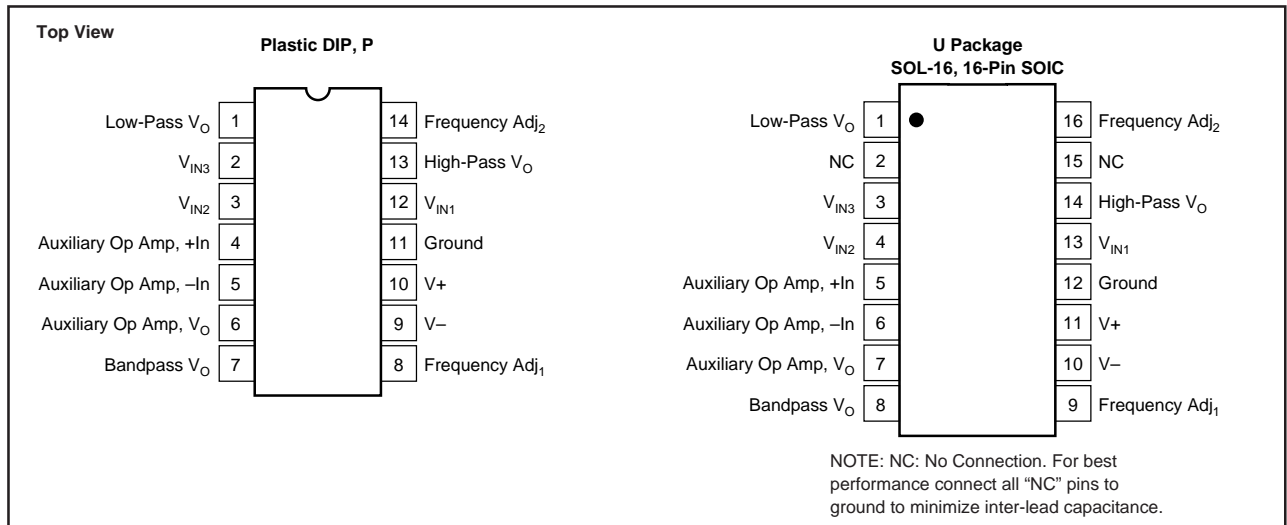

ABSOLUTE MAXIMUM RATINGS

Power Supply Voltage	$\pm 18V$
Input Voltage	$\pm V_S \pm 0.7V$
Output Short Circuit	Continuous
Operating Temperature:	
Plastic DIP, P; SOIC, U	$-40^{\circ}C$ to $+85^{\circ}C$
Storage Temperature:	
Plastic DIP, P; SOIC, U	$-40^{\circ}C$ to $+125^{\circ}C$
Junction Temperature:	
Plastic DIP, P; SOIC, U	$+125^{\circ}C$
Lead Temperature (soldering, 10s)	$+300^{\circ}C$

PACKAGE/ORDERING INFORMATION

PRODUCT	PACKAGE	PACKAGE DRAWING NUMBER ⁽¹⁾	TEMPERATURE RANGE
UAF42AP	Plastic 14-pin DIP	010	$-25^{\circ}C$ to $+85^{\circ}C$
UAF42AU	SOL-16	211	$-25^{\circ}C$ to $+85^{\circ}C$

NOTE: (1) For detailed drawing and dimension table, please see end of data sheet, or Appendix C of Burr-Brown IC Data Book.



ELECTROSTATIC DISCHARGE SENSITIVITY

This integrated circuit can be damaged by ESD. Burr-Brown recommends that all integrated circuits be handled with appropriate precautions. Failure to observe proper handling and installation procedures can cause damage.

ESD damage can range from subtle performance degradation to complete device failure. Precision integrated circuits may be more susceptible to damage because very small parametric changes could cause the device not to meet its published specifications.



APPLICATIONS INFORMATION

The UAF42 is a monolithic implementation of the proven state-variable analog filter topology. Pin-compatible with the popular UAF41 Analog Filter, it provides several improvements.

Slew Rate of the UAF42 has been increased to 10V/μs versus 1.6V/μs for the UAF41. Frequency • Q product of the UAF42 has been improved, and the useful natural frequency extended by a factor of four to 100kHz. FET-input op amps on the UAF42 provide very low input bias current. The monolithic construction of the UAF42 provides lower cost and improved reliability.

DESIGN PROGRAM

Application Bulletin AB-035 and a computer-aided design program, available from Burr-Brown, make it easy to design and implement many kinds of active filters. The DOS-compatible program guides you through the design process and automatically calculates component values.

Low-pass, high-pass, band-pass and band-reject (notch) filters can be designed. The program supports the three most commonly used all-pole filter types: Butterworth, Chebyshev and Bessel. The less-familiar Inverse Chebyshev is also supported, providing a smooth passband response with ripple in the stop-band.

With each data entry, the program automatically calculates and displays filter performance. This allows a spreadsheet-like "what if" design approach. For example, you can quickly determine, by trial and error, how many poles are required for a desired attenuation in the stopband. Gain/phase plots may be viewed for any response type.

The basic building element of the most commonly used filter types is the second-order section. This section provides a complex-conjugate pair of poles. The natural frequency, ω_n , and Q of the pole pair determines the characteristic response of the section. The low-pass transfer function is

$$\frac{V_O(s)}{V_I(s)} = \frac{A_{LP}\omega_n^2}{s^2 + s \omega_n/Q + \omega_n^2} \quad (1)$$

The high-pass transfer function is

$$\frac{V_{HP}(s)}{V_I(s)} = \frac{A_{HP}s^2}{s^2 + s \omega_n/Q + \omega_n^2} \quad (2)$$

The band-pass transfer function is

$$\frac{V_{BP}(s)}{V_I(s)} = \frac{A_{BP}(\omega_n/Q) s}{s^2 + s \omega_n/Q + \omega_n^2} \quad (3)$$

A band-reject response is obtained by summing the low-pass and high-pass outputs, yielding the transfer function

$$\frac{V_{BR}(s)}{V_I(s)} = \frac{A_{BR}(s^2 + \omega_n^2)}{s^2 + s \omega_n/Q + \omega_n^2} \quad (4)$$

The most commonly used filter types are formed with one or more cascaded second-order sections. Each section is designed for ω_n and Q according to the filter type (Butterworth, Bessel, Chebyshev, etc.) and cutoff frequency. While tabulated data can be found in virtually any filter design text, the design program eliminates this tedious procedure.

Second-order sections may be non-inverting (Figure 1) or inverting (Figure 2). Design equations for these two basic configurations are shown for reference. The design program solves these equations, providing complete results, including component values.



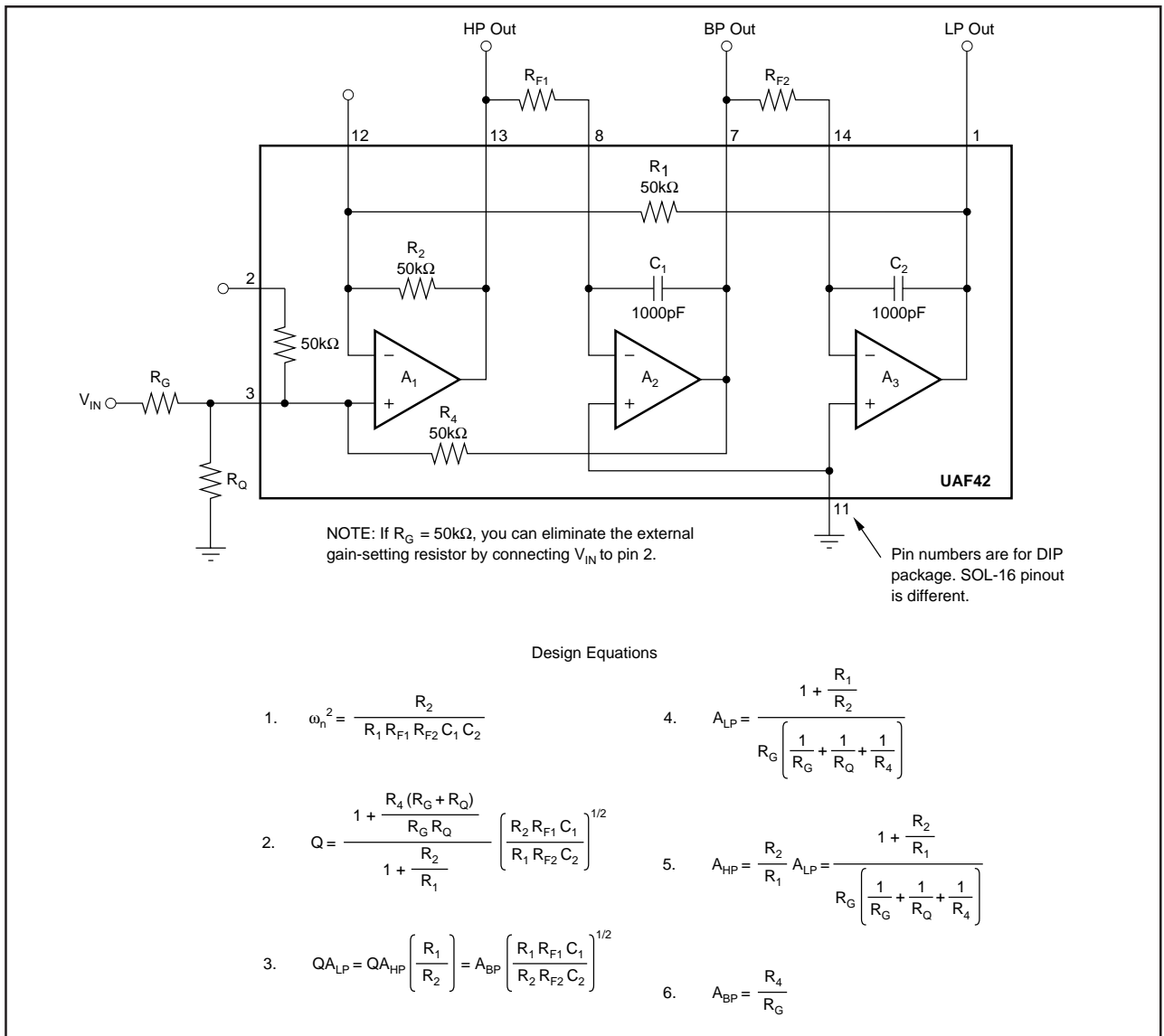
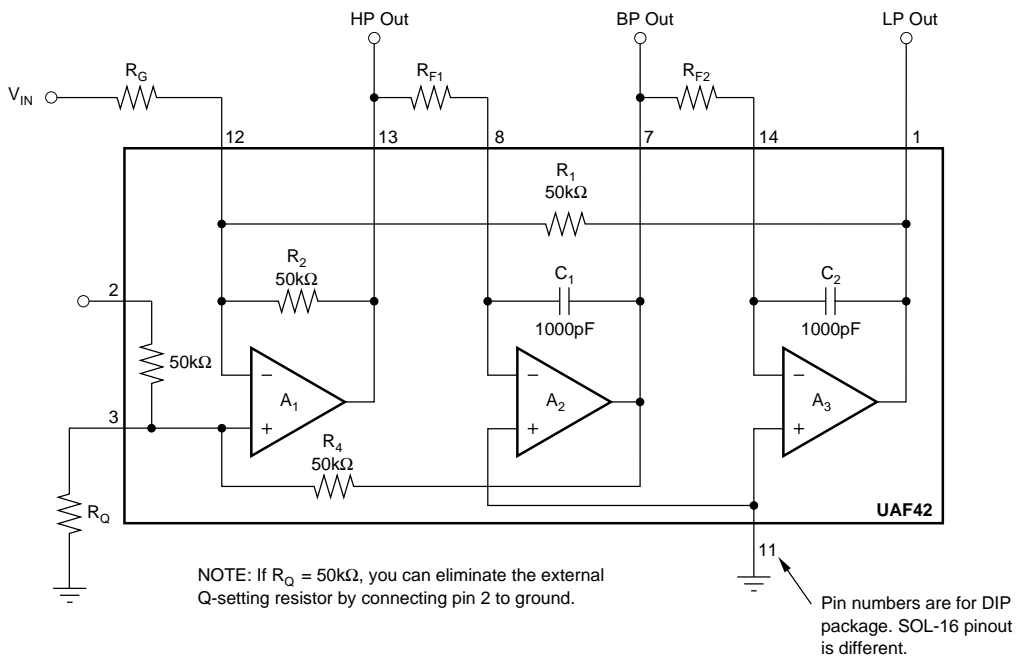

FIGURE 1. Non-Inverting Pole-Pair.



NOTE: If $R_Q = 50k\Omega$, you can eliminate the external Q-setting resistor by connecting pin 2 to ground.

Pin numbers are for DIP package. SOL-16 pinout is different.

Design Equations

$$1. \quad \omega_n^2 = \frac{R_2}{R_1 R_{F1} R_{F2} C_1 C_2}$$

$$4. \quad A_{LP} = \frac{R_1}{R_G}$$

$$2. \quad Q = \left(1 + \frac{R_4}{R_Q}\right) \frac{1}{\left[\frac{1}{R_1} + \frac{1}{R_2} + \frac{1}{R_G}\right]} \left(\frac{R_{F1} C_1}{R_1 R_2 R_{F2} C_2}\right)^{1/2}$$

$$5. \quad A_{HP} = \frac{R_2}{R_1} A_{LP} = \frac{R_2}{R_G}$$

$$3. \quad QA_{LP} = QA_{HP} \left(\frac{R_1}{R_2}\right) = A_{BP} \left(\frac{R_1 R_{F1} C_1}{R_2 R_{F2} C_2}\right)^{1/2}$$

$$6. \quad A_{BP} = \left(1 + \frac{R_4}{R_Q}\right) \frac{1}{R_G \left[\frac{1}{R_1} + \frac{1}{R_2} + \frac{1}{R_G}\right]}$$

FIGURE 2. Inverting Pole-Pair.



PACKAGING INFORMATION

Orderable Device	Status ⁽¹⁾	Package Type	Package Drawing	Pins	Package Qty	Eco Plan ⁽²⁾	Lead/Ball Finish	MSL Peak Temp ⁽³⁾
UAF42AP	ACTIVE	PDIP	N	14	25	Green (RoHS & no Sb/Br)	CU NIPDAU	N / A for Pkg Type
UAF42AP-1	OBSOLETE	PDIP	N	14		TBD	Call TI	Call TI
UAF42AU	ACTIVE	SOIC	DW	16	48	Pb-Free (RoHS)	CU NIPDAU	Level-3-260C-168 HR
UAF42AU-1	OBSOLETE	SOIC	DW	16		TBD	Call TI	Call TI
UAF42AUE4	ACTIVE	SOIC	DW	16	48	Green (RoHS & no Sb/Br)	CU NIPDAU	Level-3-260C-168 HR

⁽¹⁾ The marketing status values are defined as follows:

ACTIVE: Product device recommended for new designs.

LIFEBUY: TI has announced that the device will be discontinued, and a lifetime-buy period is in effect.

NRND: Not recommended for new designs. Device is in production to support existing customers, but TI does not recommend using this part in a new design.

PREVIEW: Device has been announced but is not in production. Samples may or may not be available.

OBSOLETE: TI has discontinued the production of the device.

⁽²⁾ Eco Plan - The planned eco-friendly classification: Pb-Free (RoHS), Pb-Free (RoHS Exempt), or Green (RoHS & no Sb/Br) - please check <http://www.ti.com/productcontent> for the latest availability information and additional product content details.

TBD: The Pb-Free/Green conversion plan has not been defined.

Pb-Free (RoHS): TI's terms "Lead-Free" or "Pb-Free" mean semiconductor products that are compatible with the current RoHS requirements for all 6 substances, including the requirement that lead not exceed 0.1% by weight in homogeneous materials. Where designed to be soldered at high temperatures, TI Pb-Free products are suitable for use in specified lead-free processes.

Pb-Free (RoHS Exempt): This component has a RoHS exemption for either 1) lead-based flip-chip solder bumps used between the die and package, or 2) lead-based die adhesive used between the die and leadframe. The component is otherwise considered Pb-Free (RoHS compatible) as defined above.

Green (RoHS & no Sb/Br): TI defines "Green" to mean Pb-Free (RoHS compatible), and free of Bromine (Br) and Antimony (Sb) based flame retardants (Br or Sb do not exceed 0.1% by weight in homogeneous material)

⁽³⁾ MSL, Peak Temp. -- The Moisture Sensitivity Level rating according to the JEDEC industry standard classifications, and peak solder temperature.

Important Information and Disclaimer:The information provided on this page represents TI's knowledge and belief as of the date that it is provided. TI bases its knowledge and belief on information provided by third parties, and makes no representation or warranty as to the accuracy of such information. Efforts are underway to better integrate information from third parties. TI has taken and continues to take reasonable steps to provide representative and accurate information but may not have conducted destructive testing or chemical analysis on incoming materials and chemicals. TI and TI suppliers consider certain information to be proprietary, and thus CAS numbers and other limited information may not be available for release.

In no event shall TI's liability arising out of such information exceed the total purchase price of the TI part(s) at issue in this document sold by TI to Customer on an annual basis.

IMPORTANT NOTICE

Texas Instruments Incorporated and its subsidiaries (TI) reserve the right to make corrections, modifications, enhancements, improvements, and other changes to its products and services at any time and to discontinue any product or service without notice. Customers should obtain the latest relevant information before placing orders and should verify that such information is current and complete. All products are sold subject to TI's terms and conditions of sale supplied at the time of order acknowledgment.

TI warrants performance of its hardware products to the specifications applicable at the time of sale in accordance with TI's standard warranty. Testing and other quality control techniques are used to the extent TI deems necessary to support this warranty. Except where mandated by government requirements, testing of all parameters of each product is not necessarily performed.

TI assumes no liability for applications assistance or customer product design. Customers are responsible for their products and applications using TI components. To minimize the risks associated with customer products and applications, customers should provide adequate design and operating safeguards.

TI does not warrant or represent that any license, either express or implied, is granted under any TI patent right, copyright, mask work right, or other TI intellectual property right relating to any combination, machine, or process in which TI products or services are used. Information published by TI regarding third-party products or services does not constitute a license from TI to use such products or services or a warranty or endorsement thereof. Use of such information may require a license from a third party under the patents or other intellectual property of the third party, or a license from TI under the patents or other intellectual property of TI.

Reproduction of information in TI data books or data sheets is permissible only if reproduction is without alteration and is accompanied by all associated warranties, conditions, limitations, and notices. Reproduction of this information with alteration is an unfair and deceptive business practice. TI is not responsible or liable for such altered documentation.

Resale of TI products or services with statements different from or beyond the parameters stated by TI for that product or service voids all express and any implied warranties for the associated TI product or service and is an unfair and deceptive business practice. TI is not responsible or liable for any such statements.

Following are URLs where you can obtain information on other Texas Instruments products and application solutions:

Products		Applications	
Amplifiers	amplifier.ti.com	Audio	www.ti.com/audio
Data Converters	dataconverter.ti.com	Automotive	www.ti.com/automotive
DSP	dsp.ti.com	Broadband	www.ti.com/broadband
Interface	interface.ti.com	Digital Control	www.ti.com/digitalcontrol
Logic	logic.ti.com	Military	www.ti.com/military
Power Mgmt	power.ti.com	Optical Networking	www.ti.com/opticalnetwork
Microcontrollers	microcontroller.ti.com	Security	www.ti.com/security
Low Power Wireless	www.ti.com/lpw	Telephony	www.ti.com/telephony
		Video & Imaging	www.ti.com/video
		Wireless	www.ti.com/wireless

Mailing Address: Texas Instruments
Post Office Box 655303 Dallas, Texas 75265